

■ AC Power for
Business-Critical Continuity

Liebert® Hipulse-U™

Fully Digital Dual DSP Controlled Transformer Based UPS





Emerson Network Power, a business of Emerson, a global company that leads by applying unique combination of industry expertise, technology, and resources to make the future of our customers' enterprises and networks possible.

We are Emerson

Emerson Network Power's broad technology base and global expertise support a full spectrum of enterprise wide solution for today's business need . We have been providing tailored solutions for protecting the operation of critical electronic systems in virtually every business segment right from customer premise equipment to global network .

Emerson. Consider It Solved.

Customers call on Emerson when the stakes are the highest. Why? Because they know that we bring them technology and engineering to create solutions for their success. Whatever their challenge, they know that with Emerson by their side, they can "Consider It Solved."

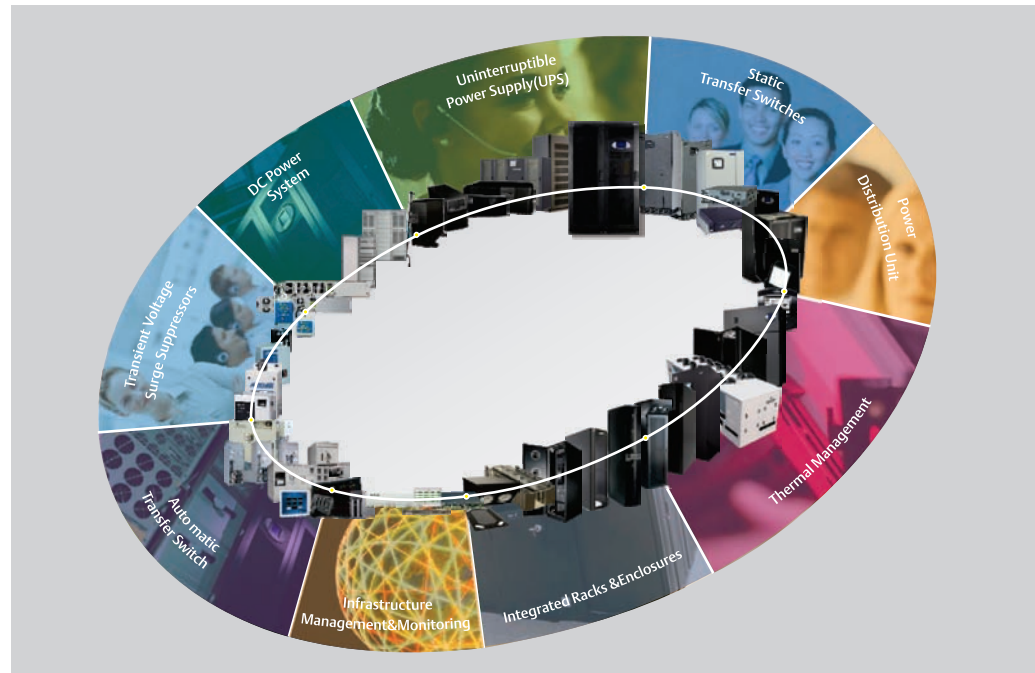

Supported by our right combination of knowledge, experience, product selection and service capability. We are the true solution provider of our customer's IT infrastructure, right from grid to chip level.

When the stakes are high, partner with Emerson Network Power to optimize your technology with "high-nines" reliability solutions specific to your infrastructure.

Addressing a Variety of Needs

The Liebert® Hipulse-U offers a reliable, scalable and user-friendly solution to ensure availability of various types of networks. The Liebert® Hipulse-U offers protection to your investment, and provide lower cost of ownership through its digital architecture and range of options which you can customize specifically for your needs



Information Technology

- Large internet Data centers
- Colocation facilities
- Server farms
- Internet Service Providers



Telecommunication

- Mobile (3G,4G)
- Fixed (including WLL)
- MSC, BSC centers



Industrial Automation

- Process control equipments
- Motion (digital drives and robotics)
- Transport Automation
- Airport automation and flight booking
- Railways and Road transport automation and ticket booking



Corporate Parks

- Banking, Insurance and Financial Services.
- Credit card operation
- Stock exchange operation
- Software Development Houses/Software Technology Parks
- BPO / KPO/EPO operation



Building Automation

- Access Control
- Security System
- Fire Alarm System



Medical Diagnostics

- Magneto Resonant Imaging
- CT Scanning
- Cath Lab
- Multiple medical imaging units



Satellite

- Uplinking
- Earth Stations
- Broadcasting & Entertainment

Feature- Loaded UPS

We have studied the emerging needs of our customers and have engineered what we have learned into the new, upgraded Liebert® Hipulse-U. Now it offers you more value and power per square meter. You will find that the Liebert® Hipulse-U offers unique features that address the needs of you business today and is designed to handle the needs that are expected in the future.

Features To Protect Your Network

- Fully Digital, twin DSP controlled
- Rated at 0.9 output power factor to deliver more active power
- Handle leading power factor loads without KW derating under specified conditions
- On-Line Double Conversion IGBT-based PWM Inverter
- Wide input voltage tolerance(+20/-20%)
- Wide input frequency range of 45Hz to 65Hz
- High overload capability of static bypass (14 times for 10 milliseconds and 10 times for 100 milliseconds)
- Capability to handle:
 - High crest factor loads
 - 100% non-linear loads
 - 100% unbalanced loads
- Built-in maintenance bypass
- Front access for spares replacement and preventive maintenance
- Easy Dual bus configuration architecture
- Adjustable frequency synchronization window up to 6% in the static bypass
- Provision of automatic battery circuit breaker instead of using conventional isolator in the PC path
- Field protocols ModBus / Jbus
- Network protocols SNMP
- Overload capability of the UPS:
 - 110% Full load for 60 minutes
 - 125% full load for 10 minutes
 - 150% full load for 1 minute
- Easy Scalability without centralised Main Static Switch (MSS)
- Compact footprint



Built Investment Protection

- Automatic battery testing
- Field settability of EOD of the battery
- Selectable times for boost charging duration of the battery (15 steps with each step of 1 hour)
- Protection against deep discharge of battery
- Battery circuit breaker instead of using AC isolator
- Short-circuit proof inverter
- Back-feed protection
- D-level lightning protection
- With 3 auxiliary power supply to ensure redundancy under any condition
- Standard dry contacts
- Choice between 6 or 12 pulse rectifier for 120kVA to 500kVA capacity range
- Choice of array of input harmonic filter options
- Compatible with Liebert® Active Harmonic Filter
- Temperature-compensated battery charging (optional)

Selected Configurations

Hipulse U is scalable to maximum 6 units using any of the following configurations to achieve either scalability or redundancy of desired percentage

1+N Configuration with Distributed bypass System

- Up to six units in parallel
- 1+N configuration without any kind of centralized static switch
- Augment the system reliability
Increase the availability of quality power following the load demand even if it was not forecasted or planned at the beginning of the project: ease of techno-economic expandability
- Enhanced the maintainability
- The total load is less than or equal to the rating of the single UPS (depending on the desired redundancy level) and is shared between all units

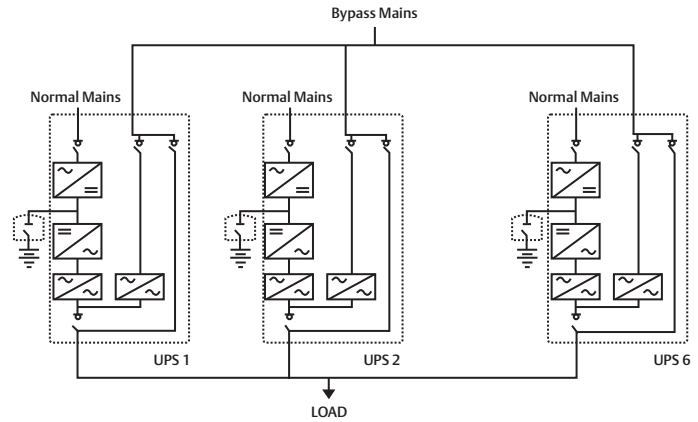

Hot Stand-by Configuration

- Feed one (Priority) or two (Priority and Normal) load banks depending on the application need
- Increase the reliability of the priority load
- Enhanced the maintainability
- Easy connection
- Can be implemented in the existing installation regardless of the UPS size, manufacturer & its control.

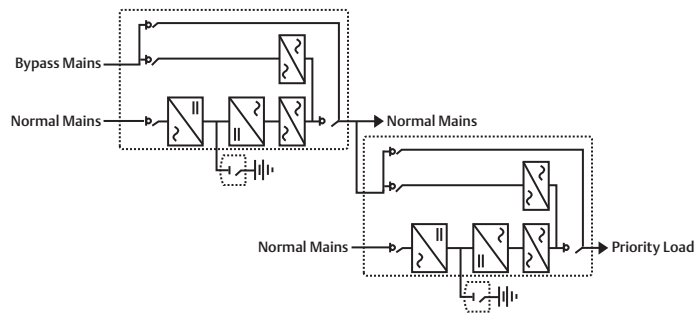

Dual Bus System with Liebert® LTS, STS2 or Hiswitch2

- Provide supply to the loads from two independent power sources
- The two sources may be different in terms of power rating and redundancy
- Synchronizes the output of two independent bus
- Automatic transfer of the load between the two sources in case of fault using Liebert® LTS
- Increase dramatically the maintainability and reliability

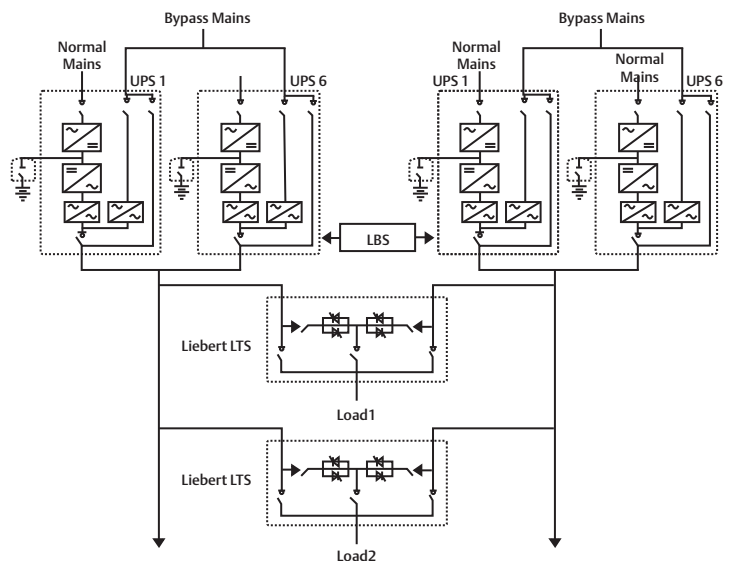

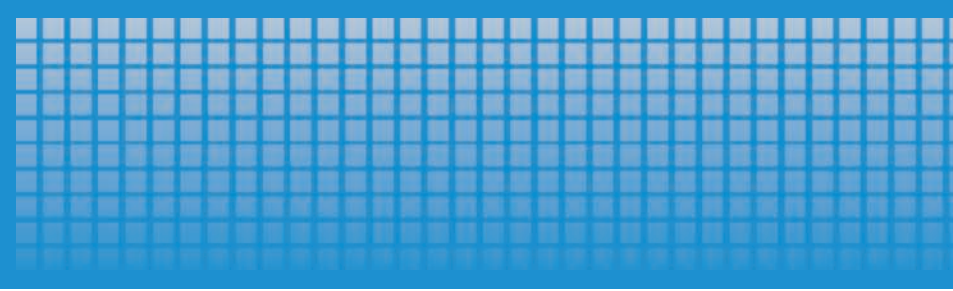

Power Communication Options

When choosing the best system to protect your mission critical applications, an important consideration would be the software and communication options, As part of our commitment to provide the best solution for you, we offer a wide range of sophisticated software and communication options for Hipulse-u.



The most extensive list of optional communication solutions for Hipulse-U UPS Systems!

- Control through Building Management Systems via Modbus and Jbus protocols
- Web-enabled Monitoring and Management through SNMP protocols
- Network Management Systems ready (HP OpenView, CA Unicenter, Novell Managewise, etc)
- Software Solutions
 - Site Monitor Software
 - Facility wide monitoring by SiteScan
 - Shutdown software for your computer equipment
- Simultaneous monitoring via different protocols
- Emerson Power Quality Monitoring solutions

Liebert Hipulse U Accessories

- **Intelligent Paralleling**
 - Intended to increase system efficiency and to reduce the operating hours on the UPS
 - This feature will put one or more paralleled units into standby operation when number of redundant modules is above the user-specified threshold
- **Liebert Active Filter**
 - Optional super filter to reduce THDi to <5% and improve input PF up to 0.93 without additional system footprint.
 - Wide range of solution specially designed for handling current harmonic on bypass at different stages
- **Isolation Transformer**
 - Additional transformer for output or bypass supply depending on application
- **Rectifier or Bypass supply**
 - This allows UPS to be configured in Single or Dual Main supply to ensure system adaptability and reliability
- **Protection Degree (IP) For Hipulse Enclosure**
 - To address stressed environmental conditions, UPS with higher than IP 20 degree of protection can be made available for most of the kVA ratings of the Hipulse-U
- **DC Ground Fault Indications**
 - This provides indication of occurrence of battery ground fault problems
- **Top Cable Entry**
 - Available for a wide range of our Hipulse-U ratings
- **Load Bus Synchronisation (LBS)**
 - Ensures the synchronisation of outputs of two independent UPS systems to form Dual Bus Architecture for High availability of Critical BUS
- **Liebert LTS, STS2 or Hiswitch2**
 - This allows critical load to be transferred between two independent , synchronized AC power sources without any risk of load disturbances
 - This allows automatic transfer of load between the two sources
- **TVSS (Transient Voltage Surge Suppressor)**
 - This offers protection from damaging transients and electrical line noises
 - This is normally connected at the bypass path of Hipulse or inside the Static Transfer Switch as an optional item



SUPPORT

Maximizing the performance and efficiency of your data center's uninterruptible power supply (UPS) and other power distribution systems requires they be properly maintained by factory-trained technicians.

Emerson Network Power, Liebert® Services has the only service organization in the world that has been factory trained on Liebert power equipment and is continuously supported and updated by the engineers who built the equipment.

Our Customer Engineers have a better knowledge of how to maintain Liebert equipment and integrate it into the overall data center infrastructure support strategy than any service provider.

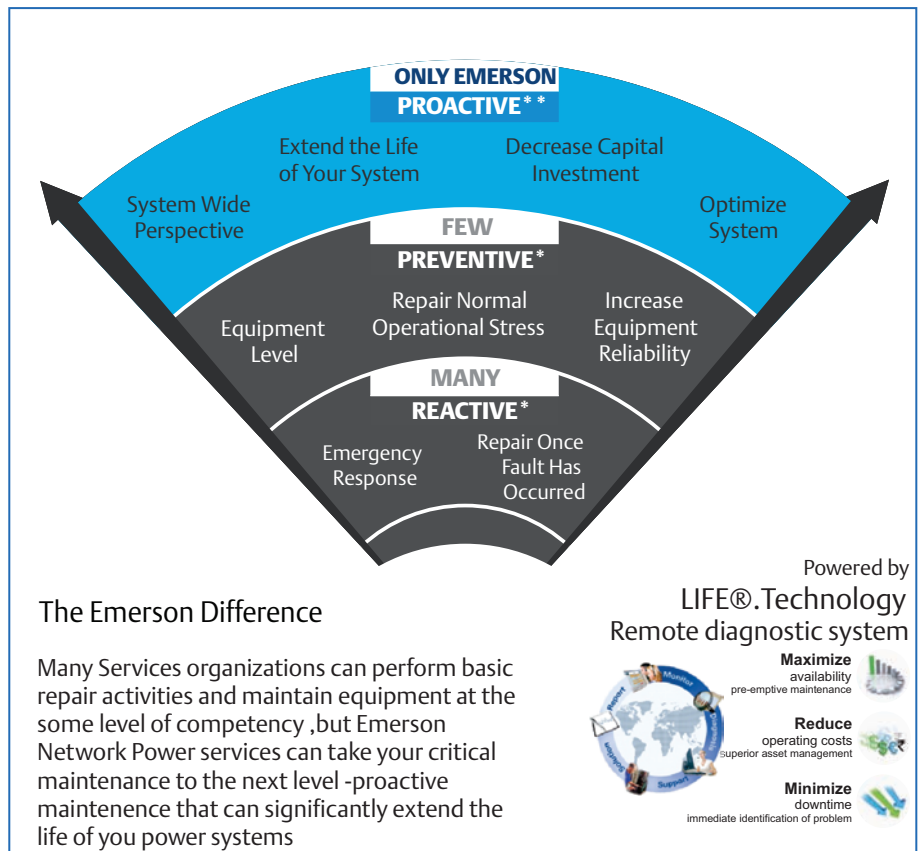

Emerson Network Power, Liebert Services

Industry Experience

As long as data centers have existed, Liebert Services has been supporting data center infrastructure and providing integrated services for mission-critical environments.

System Wide Expertise

Nobody understands Liebert power equipment, precision cooling units and electrical infrastructure better than the experts at Liebert Services.

Technical Expertise

Our knowledge of systems and how they integrate into your overall facility makes us uniquely qualified to apply the latest technology and best practices to your power, precision cooling, and battery systems.

Unparalleled Responsiveness

With Liebert Services, you have 24/7 access to a network of data center infrastructure specialists armed with

the knowledge and parts to resolve your problems. Anytime. Anywhere.

Fast, Efficient Problem Resolution

Only Liebert Services offers the right combination of industry, system, and technical expertise along with the extensive resources necessary to identify and understand any data center need and provide proactive solutions.

Nominal Rating (kVA)		30kVA	40kVA	60kVA
Rectifier Type		6P	6P	6P
Physical Characteristics				
Depth (mm)		810	810	810
Width (mm)		715	715	715
Height (mm)		1615	1615	1615
Weight (kg)		530	590	670
Input				
Voltage		380/400/415Vac 3-Wire plus Earth		
Input Voltage Range		-15%,+10%		
Frequency		50Hz or 60Hz		
Input frequency Range		45Hz to 55Hz or 55Hz to 65Hz		
Input Current Distortion with Linear load (with filter)		5% with optional filter		
Power Factor (with filter)		0.9 with optional filter		
Output				
Voltage		380/400/415V – 3 Phase with Neutral		
Frequency				
Voltage Stability	Steady State	±1%		
	Transient State	±5%		
Transient Recovery Time		20 millisecond to 1%		
Frequency Stability	Synchronized with internal clock	±0.1%		
	Synchronized with bypass	±6%(max)		
Overload Capability	101-110%	60 minutes		
	111-125%	10 minutes		
	126 - 150%	1 minute		
Voltage Distortion with Linear Load		≤ 1%		
Voltage Distortion with 100% Non-Linear Load		≤ 5%		
Permissible Load Unbalance		100%		
Non linear load capability		100%		
Phase Angle displacement accuracy	100% balanced load	± 1°		
	100% unbalanced load	± 1°		
Standards and Approvals				
General and Safety requirements for UPS (1999)		IEC 62040-1-1		
EMC requirements for UPS (2005)		IEC 62040-2		
Design & Test Methods (1999)		IEC 62040-3		

Note: Specifications considering 400V nominal voltage

Liebert® Hipulse-U™ Technical Specifications

Nominal Rating (kVA)	80	100	120		160		200		300		400		500
Rectifier Type	6P	6P	6P	12P	6P	12P	6P	12P	6P	12P	6P	12P	12P
Physical Characteristics													
Depth (mm)	855												
Width (mm)	900		1540	1250	1640	1240	1740	1640	2280	2280		2640	
Height (mm)	1900												
Weight (kg)	900		1400	1200	1750	1200	1850	1600	2550	2200	2400	2900	
Input													
Voltage	380 / 400 / 415Vac 4-wire plus ground												
Input voltage range	290 to 498Vac												
Frequency	50Hz / 60Hz												
Input frequency range	45 to 65 Hz												
Input Current Distortion with linear load (with filter)	3 to 10% with optional filter												
Power Factor (with filter)	0.88 to 0.97 with optional filter												
Output													
Voltage	380 / 400 / 415Vac 4-wire plus ground												
Frequency													
Voltage Stability	Steady state	±1%											
	Transient state	±5%											
Transient recovery time	20 milliseconds (max)												
Frequency stability	Synchronized with internal clock	±0.1%											
	Synchronized with bypass	±6%(max)											
Overload Capability	105%	60 minutes											
	125%	10 minutes											
	150%	1 minute											
	>150%	< 200 millisecond											
Voltage Distortion with Linear Load	<1%												
Voltage Distortion with 100% Non-Linear load	<5%			<3.5%									
Permissible Load Unbalance	100%												
Non linear load capability	100%												
Load handling capability without kVA derating	0.5 lagging to 0.9 lagging												
Phase Angle displacement accuracy	100% balanced load	±1°											
	100% unbalanced load	±1°											
Standards and Approvals													
General and safety requirements for UPS	IEC 62040-1												
EMC requirements for UPS	IEC 62040-2												
UPS Classification according to CEI EN 6240-3	VFI-SS-111												

Note: Specifications are subject to change without any prior notification.

Country Office

Emerson Network Power (India) Private Ltd.
Plot No. C-20, Road No. 19, Wagle Estate,
Thane (W), Maharashtra - 400 604, India.

Tel.: 91-22-33154400

Fax: 91-22-25828358

Toll Free No 18002096070

Email: marketing.india@emerson.com

 <p>2014 CIO CHOICE 2014</p>	<p>CIO CHOICE 2014 Awards (Centre Of Recognition & Excellence) Most Preferred Brand</p> <ul style="list-style-type: none"> • Integrated Data Center Solution • ICT Infrastructure Cooling • Data Center Infrastructure Management
 <p>2013 BEST PRACTICES AWARD</p>	<p>Frost & Sullivan 'Voice Of Customer' 2013</p> <ul style="list-style-type: none"> • Most Preferred UPS Brand - IT/ITES • Most Preferred UPS Brand - Manufacturing & Process Industries • Most Preferred UPS Brand - Power, Oil and Gas • Overall Customer Service Leadership (Above 20kVA) Award
 <p>2013 CIO CHOICE 2013</p>	<p>CIO CHOICE 2013 Awards (Centre Of Recognition & Excellence) - Most Preferred Brand</p> <ul style="list-style-type: none"> • Data Center (UPS) • Data Center (Cooling) • Power Distribution • Infrastructure Appliance
<p>2013 (Global recognition)</p>	<p>2013 (Global recognition) EMA Radar Report™ for Data Center Infrastructure Management 'Most Comprehensive DCIM Solution' - Trellis</p>
<p>2012 (Global recognition)</p> <p>Forrester's March 2012: "Market Overview: Data Center Infrastructure Management Solutions" report 'Dominant supplier in data center infrastructure management (DCIM)'</p>	
<p>2012 (APAC recognition)</p>  <p>2012 BEST PRACTICES AWARD</p>	<p>2010 Frost & Sullivan 'Asia Pacific Market Share Leadership 2012' - data centre cooling solutions market</p> <p>2010 Frost & Sullivan 'India UPS Market Leadership Award'</p>
 <p>ISO 9001 DNV 2007 Certificate No. REGISTERED FIRM</p>	<p>ISO 14001 REGISTERED</p>  <p>ISO 14001 REGISTERED DNV 2007 Certificate No. REGISTERED FIRM</p>
 <p>2013 FORTUNE WORLD'S MOST ADMIRABLE COMPANIES</p> <p>Emerson Among Top 50 On Fortune Survey Of "Worlds Most Admired" Companies.</p>	

While every precaution has been taken to ensure accuracy and completeness in this brochure, Emerson Network Power assumes no responsibility, and disclaims all liability for damages resulting from use of this information or for any errors or omissions.

For disposal of Batteries Please visit the below link:













<http://www.cpcb.nic.in/divisionsofheadoffice/hwmd/lead.pdf>

Note: Specifications & Features may vary based on the condition.

Emerson Network Power.

The global leader in enabling Business-Critical Continuity™.

www.emersonnetworkpower.com

- | | | | |
|---|--|--|--|
|  AC Power |  Embedded Computing |  Outside Plant |  Racks & Integrated Cabinets |
|  Connectivity |  Embedded Power |  Power Switching & Controls |  Services |
|  DC Power |  Monitoring |  Precision Cooling |  Surge Protection |

Emerson, Business - Critical Continuity and Emerson Network Power are trademarks of Emerson Electric Co. or its affiliated companies. © 2012 Emerson Electric Co.

EMR / AC Power / Hipulse-U UPS / 17.07.14

EMERSON. CONSIDER IT SOLVED.™